

powermaster

D-MG

Gearhead Operator with DC Motor and Battery Backup for Sectional and Rolling Service Doors & Grilles

STANDARD FEATURES

- BATTERY BACKUP
- SOLID STATE CIRCUITRY WITH FEEDBACK LEDs
- ON BOARD OPEN/CLOSE/STOP BUTTONS FOR SERVICE AND ADJUSTMENTS
- FIELD ADJUSTABLE BUILT-IN FUNCTIONS
- AUTO-DETECT MONITORED PHOTOBEAM
- FLOOR LEVEL DISCONNECT WITH CHAIN HOIST INTERLOCK FOR MANUAL OPERATION



Complete selection of control stations & accessories are available.

All door operators are required to have a monitored safety system, such as monitored photo eyes and/or monitored 2 or 4 wire obstruction sensing edge. In addition, an ancillary device may be used. The primary device must be a constantly monitored, anti entrapment/safety device.

 [Facebook.com/PowerMasterOperators](https://www.facebook.com/PowerMasterOperators)

www.PowerMasterNY.com
SERVICING THE INDUSTRY SINCE 1969

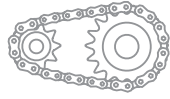

SPECIFICATIONS & FEATURES

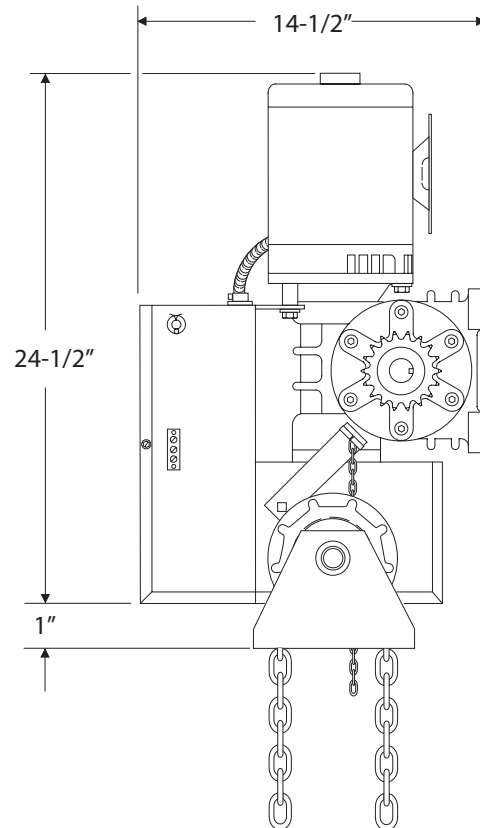
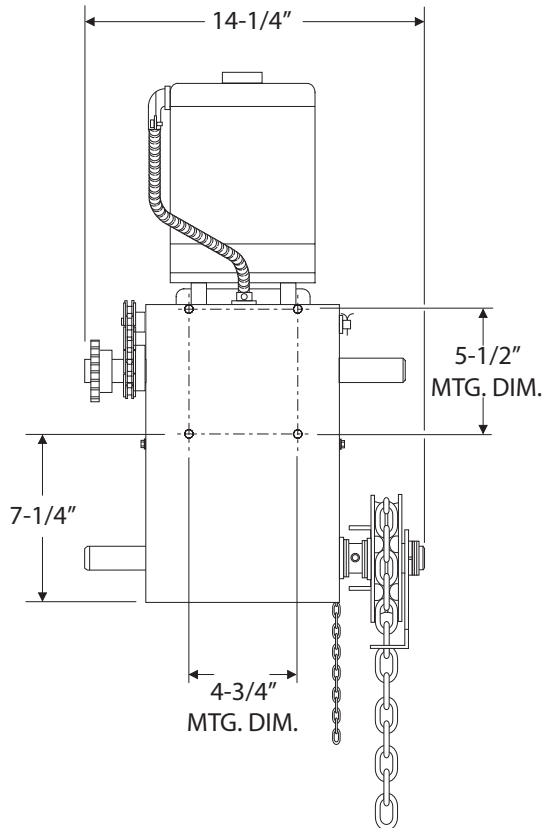

MOTOR: 588 WATTS (1/2 HP EQUIVALENT), 24VDC

POWER OPTIONS: 115VAC, 1 PHASE

SELECTABLE OPERATING MODES B2, C2, D1, E2, T, TS

FIELD ADJUSTABLE BUILT IN FUNCTIONS INCLUDING:
TIMER TO CLOSE, MID-STOP, DELAY ON REVERSE,
LOCK BAR SENSING, MAXIMUM RUN TIME, ETC.

HEAVY DUTY #50 ROLLER CHAIN AND DRIVE
SPROCKET INCLUDED

MECHANICALLY SELF LOCKING GEAR REDUCER
(OIL BATH TYPE)

BAKED ON, BLACK POWDER COAT FINISH

ADJUSTABLE TORQUE LIMITING CLUTCH OPTIONAL

SHIPPING WEIGHT: APPROX. 132 LBS

CAUTION

A moving door can cause serious injury or death! Carefully read and follow all safety instructions, precautions, and guidelines when installing and using this product. Motorized doors are for vehicles only. Pedestrians must use a separate entrance. NO ONE SHOULD CROSS THE PATH OF A MOVING DOOR! Proper reversing devices must be installed to avoid all hazards and entrapment. Eliminate all hazards and entrapment areas. Warning signs must be permanently installed and visible to traffic and pedestrians. Never allow children to operate or play with controls. Follow UL 325 and ASTM F220-02 standards. Do not install this product unless all hazards and entrapment points are protected.

