

powermaster

D-GJ

Gear Reduced Jackshaft Operator for Rolling Service Doors, Rolling Grilles, and Counter Shutters.

DGJ

STANDARD FEATURES

- BATTERY BACKUP
- CONTINUOUS DUTY OPERATION
- WORM GEAR REDUCTION
- SOLID STATE CIRCUITRY WITH FEEDBACK LEDs
- ONBOARD OPEN/CLOSE/STOP BUTTONS FOR SERVICE AND ADJUSTMENTS
- AUTO-DETECT MONITORED PHOTOBEAM
- FLOOR LEVEL DISCONNECT



*Complete selection of control stations
& accessories are available.*

All door operators are required to have a monitored safety system, such as monitored photo eyes and/ or monitored 2 or 4 wire obstruction sensing edge. In addition, an ancillary device may be used. The primary device must be a constantly monitored, anti entrapment/safety device.



Facebook.com/PowerMasterOperators

www.PowerMasterNY.com
SERVICING THE INDUSTRY SINCE 1969

SPECIFICATIONS & FEATURES

MOTOR: 588 WATTS (1/2 HP EQUIVALENT), 24VDC

POWER REQUIREMENTS: 115VAC

CONTINUOUS DUTY OPERATION

SOLID STATE CIRCUITRY WITH POWER AND PROGRAM FEEDBACK LEDS

3-BUTTON NEMA 1 CONTROL STATION INCLUDED

HEAVY DUTY #41 ROLLER CHAIN & DRIVEN SPROCKET FOR FINAL DRIVE INCLUDED

POSITIVE CHAIN DRIVEN ROTARY LIMIT SWITCHES

FIELD ADJUSTABLE BUILT IN FUNCTIONS INCLUDING: TIMER TO CLOSE, MID-STOP, DELAY ON REVERSE, LOCK BAR SENSING, MAXIMUM RUN TIME, ETC.

TERMINALS LABELED AND GROUPED BY FUNCTION

SELECTABLE OPERATING MODES B2, C2, D1, E2, T, TS

BAKED ON, BLACK POWDER COAT FINISH

SHIPPING WEIGHT: APPROX. 90 LBS

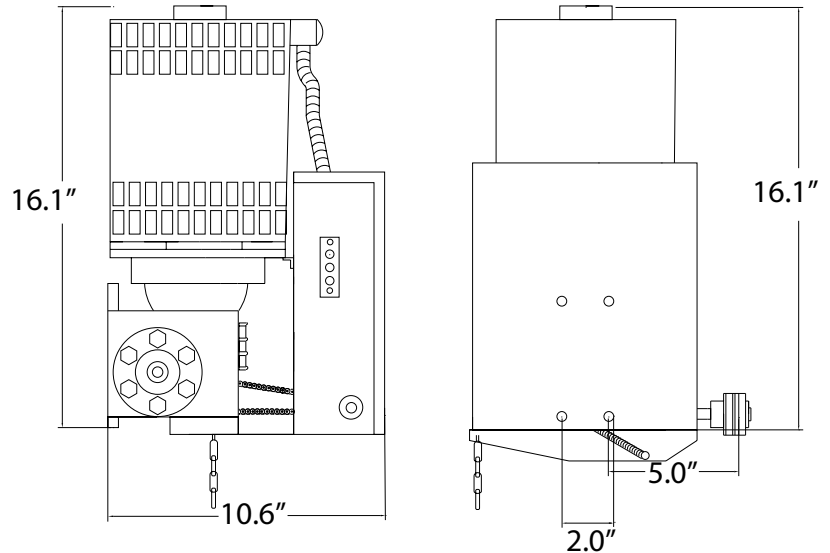

OPTIONAL EQUIPMENT

- ADDITIONAL SAFETY EDGE (CONTACT SAFETY SENSOR)
- ADDITIONAL PHOTO CELL (NON-CONTACT SAFETY SENSOR)
- CONTROL STATIONS AND ACCESSORIES
- ADJUSTABLE TORQUE LIMITING CLUTCH

CAUTION

A moving door can cause serious injury or death! Carefully read and follow all safety instructions, precautions, and guidelines when installing and using this product. Motorized doors are for vehicles only. Pedestrians must use a separate entrance. **NO ONE SHOULD CROSS THE PATH OF A MOVING DOOR!** Proper reversing devices must be installed to avoid all hazards and entrapment. Eliminate all hazards and entrapment areas. Warning signs must be permanently installed and visible to traffic and pedestrians. Never allow children to operate or play with controls. Follow UL 325 and ASTM F220-02 standards. Do not install this product unless all hazards and entrapment points are protected.

