

# powermaster

## CGH

**Center Mounted Gearhead Operator for Sectional Doors requiring high-speed manual operation in the event of a power failure.**

### STANDARD FEATURES

- HIGH STARTING TORQUE MOTOR WITH FULL OVERLOAD PROTECTION
- WORM GEAR REDUCTION & SOLENOID BRAKE
- SOLID STATE CIRCUITRY WITH POWER AND PROGRAM FEEDBACK LEDs
- ONBOARD OPEN/CLOSE/STOP BUTTONS FOR SERVICE AND ADJUSTMENTS
- AUTO-DETECT MONITORED PHOTOBEAM
- FLOOR LEVEL DISCONNECT & ELECTRICAL INTERLOCK SWITCH FOR MANUAL OPERATION



*Complete selection of control stations  
& accessories are available.*

All door operators are required to have a monitored safety system, such as monitored photo eyes and/or monitored 2 or 4 wire obstruction sensing edge. In addition, an ancillary device may be used. The primary device must be a constantly monitored, anti entrapment/safety device.



Facebook.com/PowerMasterOperators

**www.PowerMasterNY.com**  
**SERVICING THE INDUSTRY SINCE 1969**

**SPECIFICATIONS & FEATURES**

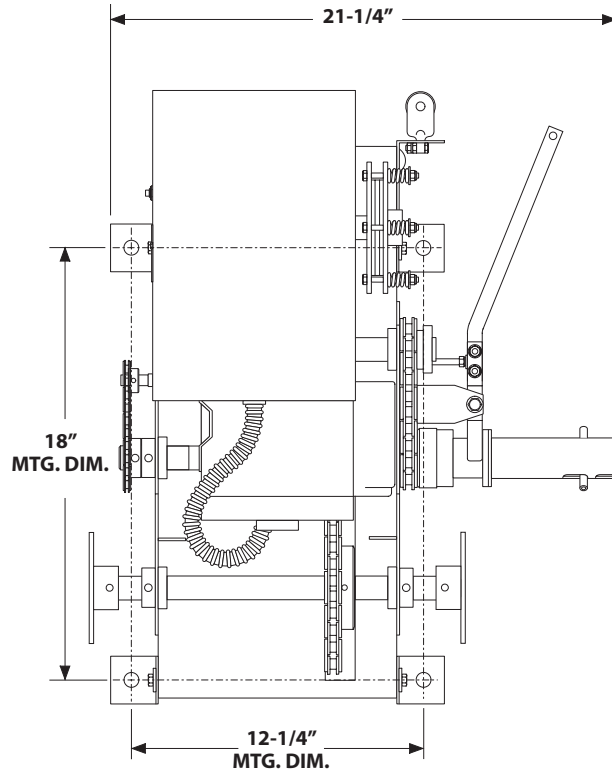
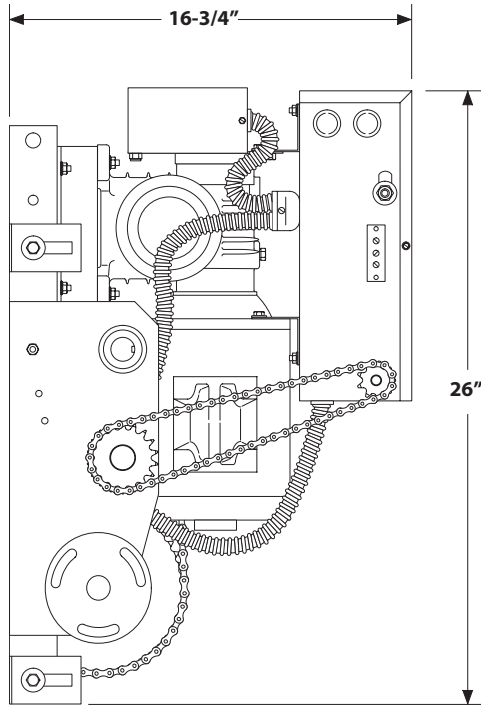

**AVAILABLE HORSE POWER:** 1/2 HP - 1 HP

**POWER OPTIONS:** 115/230 VOLTS, 1 PHASE; OR 208/230/460 VOLTS, 3 PHASE

SELECTABLE OPERATING MODES B2, C2, D1, E2, T, TS

FIELD ADJUSTABLE BUILT IN FUNCTIONS INCLUDING: TIMER TO CLOSE, MID-STOP, DELAY ON REVERSE, LOCK BAR SENSING, MAXIMUM RUN TIME, ETC.

POSITIVE CHAIN DRIVEN ROTARY LIMIT SWITCHES

HEAVY DUTY #50 ROLLER CHAIN AND DRIVE SPROCKET INCLUDED

ADJUSTABLE TORQUE LIMITING CLUTCH

BAKED ON, BLACK POWDER COAT FINISH

**SHIPPING WEIGHT:** APPROX. 185 LBS

**CAUTION**

A moving door can cause serious injury or death! Carefully read and follow all safety instructions, precautions, and guidelines when installing and using this product. Motorized doors are for vehicles only. Pedestrians must use a separate entrance. **NO ONE SHOULD CROSS THE PATH OF A MOVING DOOR!** Proper reversing devices must be installed to avoid all hazards and entrapment. Eliminate all hazards and entrapment areas. Warning signs must be permanently installed and visible to traffic and pedestrians. Never allow children to operate or play with controls. Follow UL 325 and ASTM F220-02 standards. Do not install this product unless all hazards and entrapment points are protected.

